

newline



Catalog

.....

Symbol Conventions	03
Safety Instruction	04
1.Parts and Functions	07
1.1 Parts.....	07
1.2 Ports.....	10
1.3 Remote Controller	12
2.Installation Guide	14
2.1 Safety Precautions	14
2.2 Installation Precautions	15
2.3 Installation	17
3.Turning On/Off	19
3.1 Power On	19
3.2 Power Off	19
4.Operating the Intelligent Display	20
4.1 Boot-up Screen.....	20
4.2 Welcome page.....	20
4.2.1 Newline Cast.....	21
4.2.2 Newline VCS.....	21
4.2.3 File Management.....	22
4.2.4 Applications	22
4.3 Menu Page.....	25
4.3.1 Picture.....	26
4.3.2 Sound.....	27
4.3.3 System.....	28
4.4 Input.....	29
4.5 Settings	29
4.5.1 Network & Internet.....	30
4.5.2 System Settings.....	31
4.5.3 Remotes & accessories	33



5.Serial Port Control	34
6.Formats Supported by Multi-media	37
7.FAQ & Troubleshooting	38
8.Maintenance Tips	39
9.Technical Parameters	40
10.More Information	42

Welcome to the world of **Newline**.

Thank you for choosing the **Newline** STV series Interactive Intelligent Display. Please use this document to get the most out of your screen.

This device complies with part 15 of the FCC Rules. Operation is subject to the following two conditions:(1) This device may not cause harmful interference, and (2) this device must accept any interference received, including interference that may cause undesired operation.

NOTE 1: This equipment has been tested and found to comply with the limits for a Class B digital device, pursuant to part 15 of the FCC Rules. These limits are designed to provide reasonable protection against harmful interference in a residential installation. This equipment generates, uses and can radiate radio frequency energy and, if not installed and used in accordance with the instructions, may cause harmful interference to radio communications. However, there is no guarantee that interference will not occur in a particular installation. If this equipment does cause harmful interference to radio or television reception, which can be determined by turning the equipment off and on, the user is encouraged to try to correct the interference by one or more of the following measures:

- Reorient or relocate the receiving antenna.
- Increase the separation between the equipment and receiver.
- Connect the equipment into an outlet on a circuit different from that to which the receiver is connected.
- Consult the dealer or an experienced radio/TV technician for help.

NOTE 2: Any changes or modifications to this unit not expressly approved by the party responsible for compliance could void the user's authority to operate the equipment.

The symbol of the crossed out wheeled bin indicates this machine should not be placed in municipal waste. Instead, dispose of waste equipment by handing it over to a designated collection point for the recycling of electrical and electronic equipment.



Energy Star Compliance.



Signage Displays with Plug-in Module.

As an ENERGY STAR Partner, Newline Interactive Inc., has followed the EPA's enhanced Product qualification and certification process to ensure that the products marked with the ENERGY STAR logo are ENERGY STAR qualified per the applicable ENERGY STAR guidelines for energy efficiency. The logo appears on the pen tray near front connections on all ENERGY STAR qualified Signage Displays.

The ENERGY STAR program for Signage Displays was created by EPA to promote energy efficiency and reduce air pollution through more energy-efficient equipment in offices, classrooms and factories. One way that a product achieve this goal is by using a power management feature to reduce power consumption when the product is not in use.

In the event that brightness settings or power mode settings are changed by the user, energy consumption of the display may increase beyond the limits required for ENERGY STAR certification.

Additional information on the ENERGY STAR program and its environmental benefits are available on the EPA ENERGY STAR Power Management website at <http://www.energystar.gov/powermanagement>.



Additional information on the ENERGY STAR program and its environment benefits are available on the EPA ENERGY STAR website at <http://www.energystar.gov>

For production, above information will need to be available for the Energy Star V8 build from 27th January 2020.

Symbol Conventions







.....

Symbols are used in this document to indicate operations that need particular attention. The symbols are defined as follows:



 NOTE	Provides additional information to supplement operation in the main text.
 CAUTION	Indicates a potentially hazardous situation that, if not avoided, could result in equipment damage, data loss, performance deterioration, or unanticipated results.
 WARNING	Indicates a hazard with risk that, if not avoided, could result in death or injury.

Safety Instruction



For your safety, please read the following instruction before you use the machine. Serious injury or property damage may be caused by improper operations. Do not try to repair the machine on your own.

 WARNING	
	<p>Disconnect the machine from power supply immediately if major failures occur.</p> <p>Major failures include the following:</p> <ul style="list-style-type: none"> • Smoke, peculiar smell or abnormal sound is discharged from the machine. • No image or sound is displayed, or the image error occurs. <p>In the preceding scenarios, do not continue to use the machine. Disconnect power supply immediately and contact professional staff for troubleshooting.</p>
	<p>Do not drop liquid, metal or anything combustible into the machine.</p> <ul style="list-style-type: none"> • If any liquid or metal is dropped into the machine, power off the machine and disconnect power supply, then contact professional staff for solutions. • Pay attention to children when they are close to the machine. <p>Put the machine on a stable surface.</p> <p>An unstable surface includes and does not limited to an inclined plane, a shaky stand, desk or platform, which might cause turnover and damage.</p>
	<p>Do not open the cover or change the machine on your own.</p> <p>High voltage components are installed in the machine. When you open the cover, high voltage, electric shock, or other dangerous situations may occur. If inspection, adjustment, or maintenance is required, contact the local distributor for help.</p>
	<p>Use the specified power supply.</p> <ul style="list-style-type: none"> • To prevent the machine from being damaged, do not use any types of power cables other than the one provided with the machine. • Use a three-wire socket and ensure that it is properly grounded. • Pull out the power plug from the socket if the machine is not used for a long period. <p>Clean the dust and metal on the power plug regularly.</p> <ul style="list-style-type: none"> • Fire or electric shock may be caused if the machine is powered on, when you are cleaning. • Pull out the power plug before cleaning it with a dried cloth.
	<p>Do not put items on the top of the machine.</p> <ul style="list-style-type: none"> • Do not put items, such as a container for liquid (a vase, flowerpot, cosmetics or liquid medicine) on the top of the machine. • If any water or liquid is spilled on the machine, a short circuit may occur and cause fire or electric shock. • Do not walk on or hang any items on the machine.

WARNING

	<p>Do not install the machine in an improper place.</p> <ul style="list-style-type: none">• Do not install the machine in humid places, such as the bathroom, the shower room, near windows, or outdoor environments that experience rain, snow or other harsh weather. Avoid installation near hot spring vapor. The preceding environments may cause faults in the machine or electric shock under extreme conditions.• Do not put exposed fire source, such as an ignited candle, on the machine.
	<p>Pull out the power plug during thunderstorms.</p> <ul style="list-style-type: none">• Do not touch the machine during a lighting storm to avoid electric shock.• Install or place components that supply high enough voltage to cause personal injury out of the reach of children.
	<p>Do not touch the power cable with wet hands.</p>

CAUTION

	<p>Do not install the machine in high temperature environments.</p> <ul style="list-style-type: none">• Do not install the machine near a heat source, such as a radiator, a heat reservoir, a stove or other heating machines.• Do not expose the machine to direct sunlight, which may cause high temperatures and subsequent faults in the machine.
	<p>For transport:</p> <ul style="list-style-type: none">• Pack the machine for transport or maintenance by using the cartons and cushioning material provided with the machine.• Vertically move the machine during transport. The screen or other components are easily broken if the machine is moved by an improper way.• Before you move the machine, disconnect all external connections and separate all toppling preventing machines. Move the machine carefully to prevent it from being hit or squeezed, especially the screen, which may cause injury if broken.
	<p>Do not cover or block up any vents on the machine.</p> <ul style="list-style-type: none">• Any overheated components may cause fire, damage the machine, and shorten the service life.• Do not lay the machine down where the venting surface will be covered.• Do not install the machine on a carpet or cloth.• Do not use a cloth such as table cloth to cover the machine.

CAUTION

Keep away from the machine when you use a radio.

The machine complies with the international EMI standard to prevent radio interference. However, interference may still exist and cause noise in the radio. If noise occurs in the radio, try the following solutions.

- Adjust the direction of the radio antenna to avoid the interference from the machine.
- Keep the radio away from the machine.

Use the battery correctly.

- Galvanic corrosion, electric leakage, and even fire may be caused by improper battery usage.
- It is recommended to use the designated type of battery and install the battery by correct electrodes (positive and negative).
- Do not install and use new battery with a used one.
- Take out the battery if the remote control is not used for a long period.
- Do not expose the battery to overheated environments such as sunlight and firing.
- Dispose of the used battery based on your local regulations.

Do not damage the power cable.

- Do not damage, change, twist, bend, or forcibly drag the power cable.
- Do not put weights (such as the machine itself) on the power cable.
- Do not forcibly drag the cable when you pull out the power plug. If the power cable is damaged, please contact the local distributor to repair or replace it.
- The power cable in the accessory box is for this machine only. Do not use it on other machines.

Additional advice:

- Use the machine in an environment with comfortable lighting. It is harmful to your eyes to watch in a too bright or too dark environment.
- Relax your eyes after a period of time for watching.
- Keep sufficient distance from the machine to protect your eyes and prevent eyestrain.
- Adjust the volume to an appropriate level, especially at night.
- Use amplifier equipment as the audio input source with caution. If you must use amplifier equipment, the input power should not exceed the maximum of speaker power. Otherwise, the speaker can become overpowered and damaged.



1

Parts and Functions

Parts

◆ Front View

- STV-4324 / STV-5524 / STV-6524 / STV-7524 / STV-8524 / STV-9824:

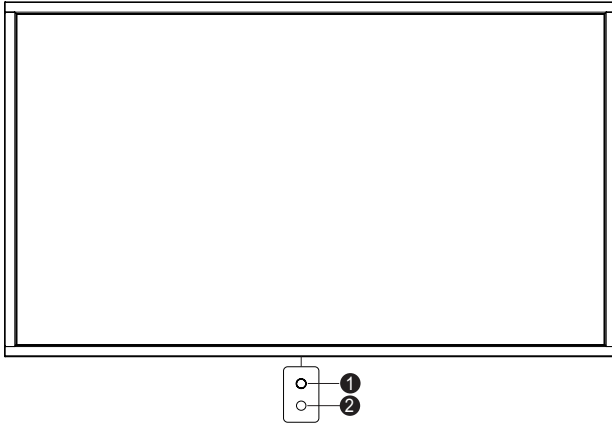

◆ Rear View

- STV-4324 / STV-5524:

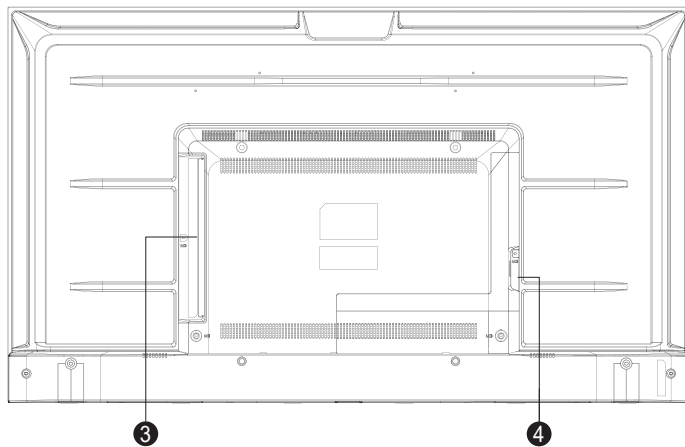

- STV-6524 / STV-7524:

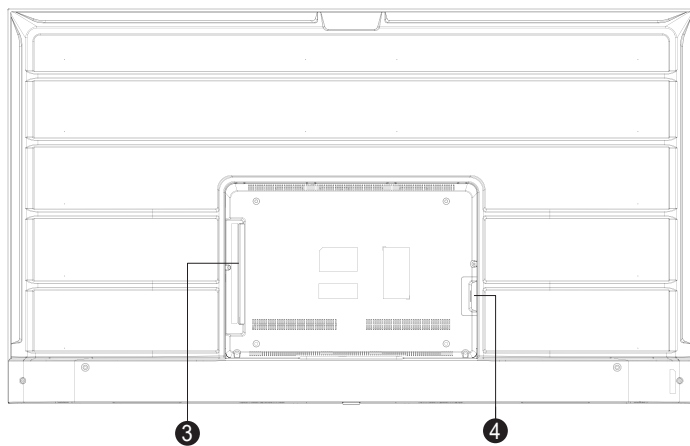

- STV-8524:

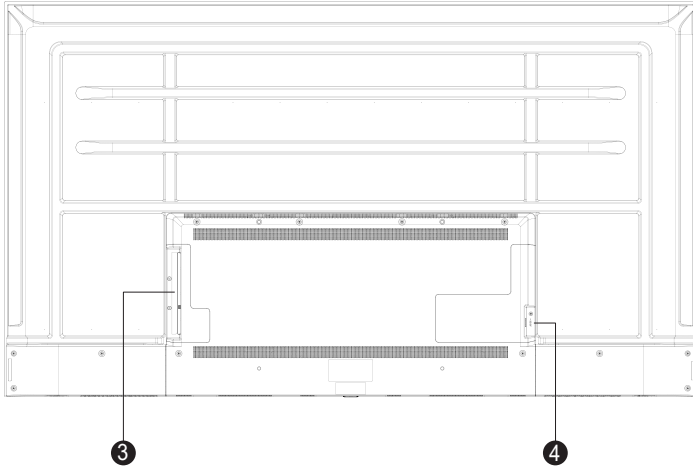

- STV-9824:

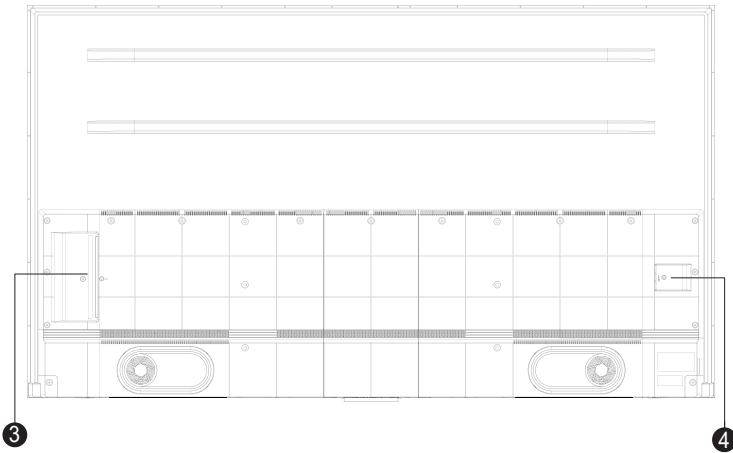

- ① Indicator Light
- ② Power Switch
- ③ Rear Ports
- ④ Power Supply Plug

◆ Rear Ports

CAUTION

- Please use the supplied cable in the accessory box or the HDMI association certified shielded cable to better ensure the signal quality.
- While HDMI and Display Port offer support for cables of varying lengths, the maximum cable length that Newline recommends for optimal performance is 3 meters (10 feet) for HDMI and 1.8 meters (around 6 feet) for Display Port. Using cable longer than recommended length may cause data loss and a negative impact to display quality.

• Right interface

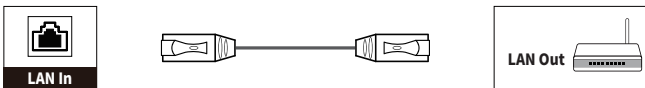
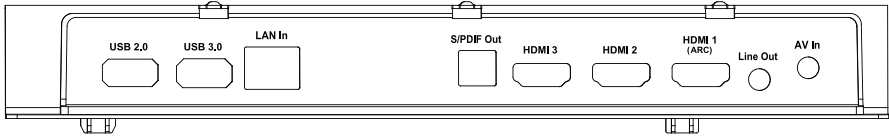

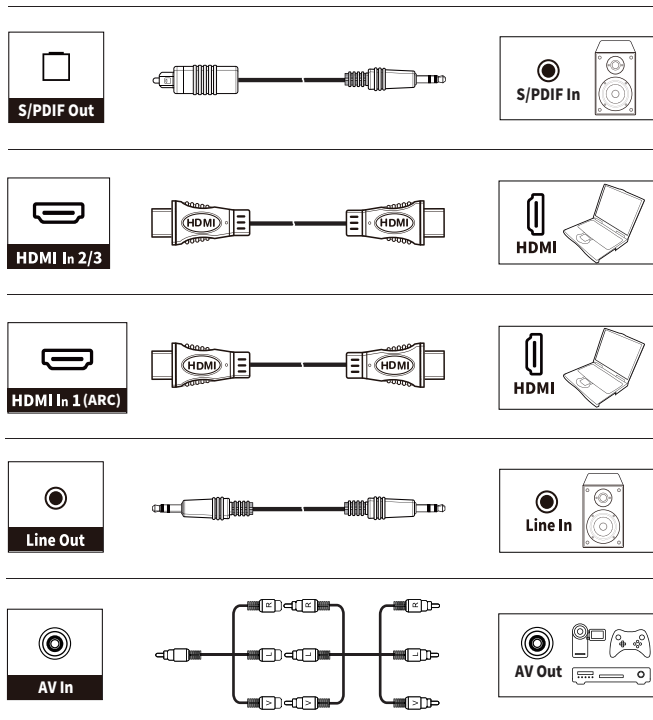

 **Note**

Please do not connect a 2.4G wireless mouse and USB 3.0 devices simultaneously, on the left back side of the display, in order to avoid the interference.

Remote Control















CAUTION

Carefully read the following instructions before using the remote control to avoid possible faults:

- Do not drop or damage the remote control.
- Do not spill water or other liquids on the remote control.
- Do not place the remote control on a wet object.
- Do not place the remote control under direct sunlight or near an overheating heat source.



Buttons	Operations
	Power on/off.
	Mute/Unmute Audio.
	Go back to Home page
	Open the system menu.
	Up/Down/Left/Right
OK	Confirm/OK.
	Return to Previous/Exit
	To select input source.
USB	To access Media Player.
	To control the volume.
	To access WiFi channel and wired network channel under settings.
	Open/turn off the wireless mouse mode
	To display the Settings menu.
	To access application list page.
	No function.

2

Installation Guide

Safety Precautions

◆ Installation Environment



Avoid Electric Shock



Avoid Strong Magnetic Field



Keep Temperature Below 120° F ($\leq 50^{\circ}\text{C}$)



Keep Relative Humidity Under 70%



Keep Away From Combustible Vapors (gas leaks, etc.)



Avoid Any Corrosive Liquids



Do Not Use Outdoors



Do Not Install Tilted

◆ Installation Direction



Hang the Product Horizontally

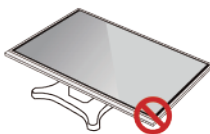

Do Not Lay Flat

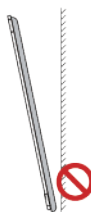

Do Not Install Tilted

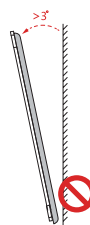

Do Not Install Tilted 75/85/98inch

Installation Precautions

- When using a mobile stand, ensure that the weight of the machine is less than the loading capacity of the mobile stand.
- When using the wall-mount bracket, ensure that the wall can support the weight of the machine. We recommend that the wall surface be reinforced and have a loading capacity 4 times of the weight of the machine. Consult a professional installer for wall-mount installation.

Note

- The company does not undertake relevant legal responsibility for any problems caused by improper operation, if the third party mobile stand, or wall-mount bracket is beyond the scope of the machine.
- Do not install the machine where it might be hit by a door.

◆ Vertical installation

When installing, try to keep the machine vertical. Excessive tilt angle may cause the screen glass to fall off or the machine to collapse.

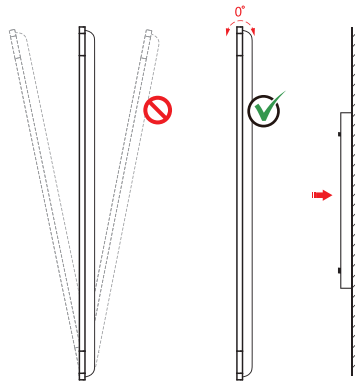

 Note

For any problem, please contact our support desk. Our company is not responsible for any damage or losses incurred by users if the users fails to follow the instructions.

◆ **Ventilation**

Ensure adequate ventilation and/or air conditioning environment. We recommend keeping certain distances from the side of the machine to the wall or panels. Ventilation requirements are shown in following figure.

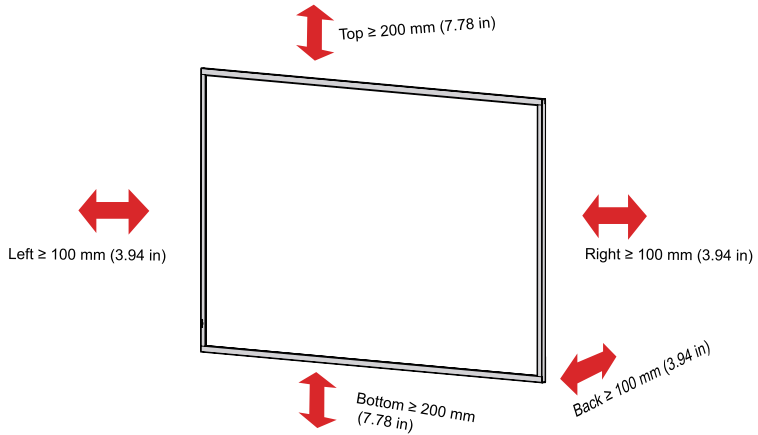

Installation

The dimensions of the four bracket mounting holes on the back panel are VESA MIS-F compliant. Dimensions of the mounting holes on the back panel are shown on the following figure.

- STV-4324/STV-5524: 300 x 300 mm /11.81 x 11.81in;
- STV-6524/STV-7524: 400 x 300 mm /15.75 x 11.81in;
- STV-8524: 500 x 400 mm/19.68 x 15.75 in;
- STV-9824: 800 x 200 x 200 mm/31.50 x 7.87 x 7.87in.

Note

- Consult a professional installer to install the machine.

43"/55"

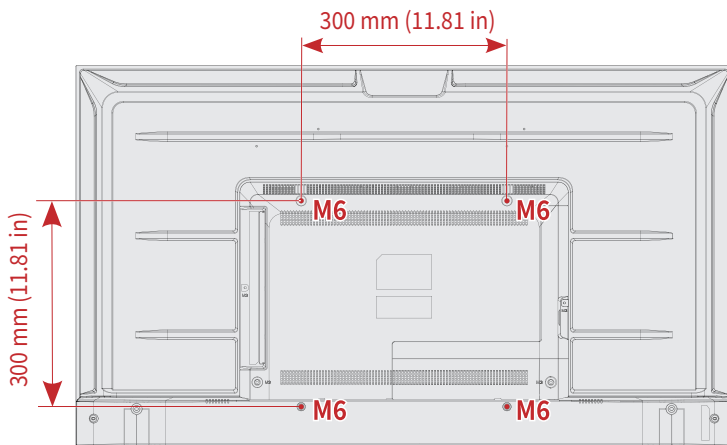

65"/75"

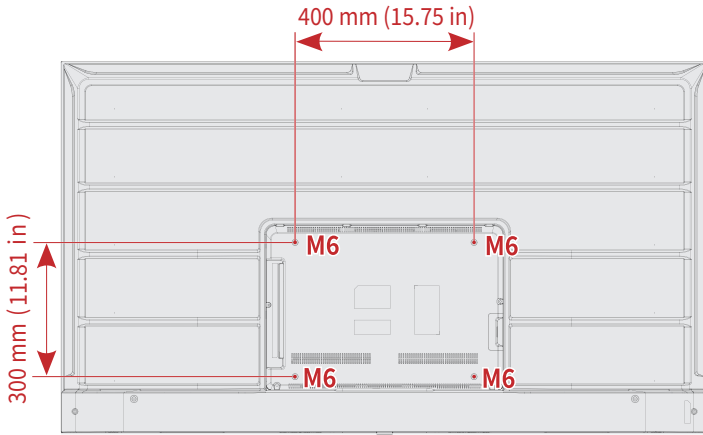

85"

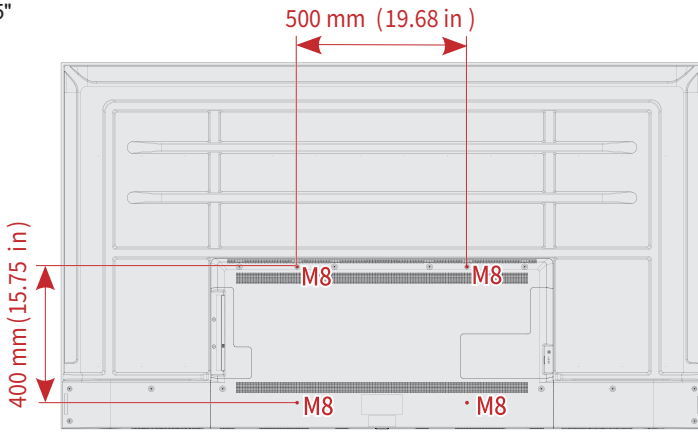

98"

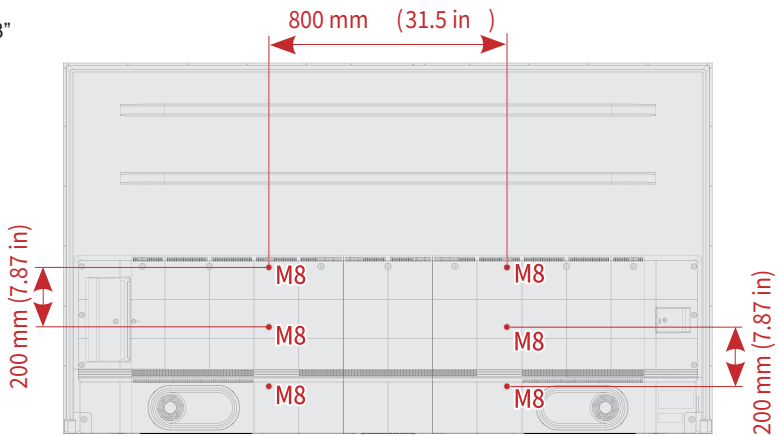

3

Turning On/Off

Power On

Step 1: Plug the power supply into the power outlet fully and plug the power connector into the side of the machine. Ensure the power is in the range of 100 V to 240 V with frequency at 50 Hz/60 Hz \pm 5%.

 **Note**

The power outlet should be installed near the machine and shall be easily accessible.

Step 2: Press the “Power” button on the bottom or  on the remote control.

Power Off

Step 1: Press the “Power” button on the bottom or press  on the remote control, the power indicator will turn to red.

Step 2: If you are not going to use the display for an extended period of time, we recommend you to unplug the power cord.

4

Operating the Intelligent Display

Boot-up Screen

When the display is turned on, screen will show the boot-up page. As shown in the following figure.

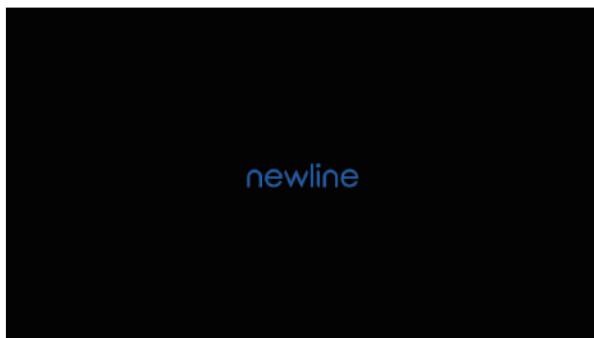

Welcome page

System enter the Welcome page after boot-up. Welcome page will display logo, time, date, Newline Cast, Newline VCS, File Management, Applications and Wi-Fi status icon, as shown in the following figure.

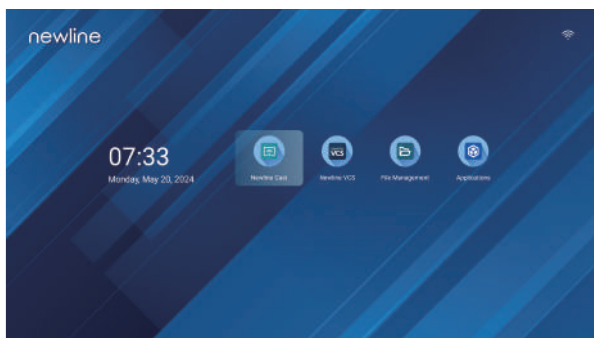

◆ Newline Cast

Select **Newline Cast** on the Welcome page to enter screen sharing mode. On screen directions will appear for you to follow in order to wirelessly cast to the display, as shown in the following figure:

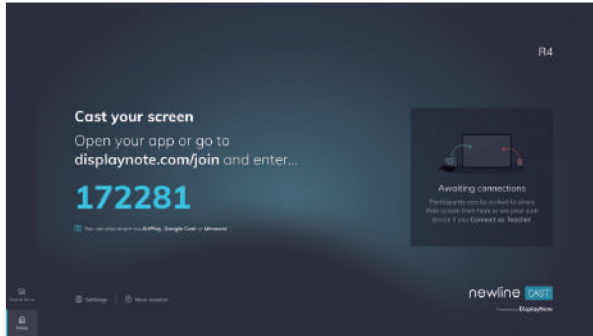

◆ Newline VCS

Select **Newline VCS** to enter the Newline VCS application, as shown in the following figure:



◆ File Management

Select **File Management** to view MultiMedia. Click this item to select file type (Word or Media), you can preview all files in the internal storage and storage devices connected via USB ports.

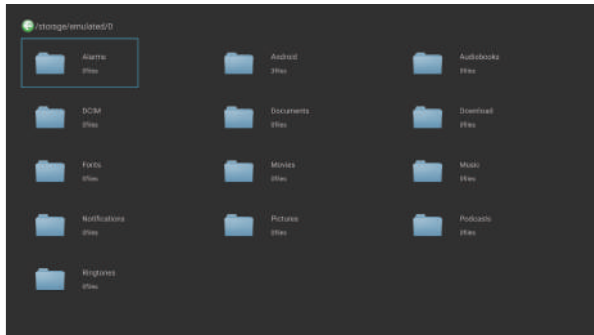
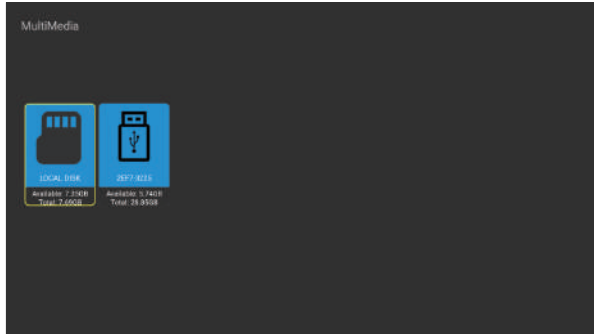

◆ Applications

Select **Applications** or press the button  on the remote control to enter the application list. **Applications** displays all pre-installed applications. Select the icon of an application to run the application.

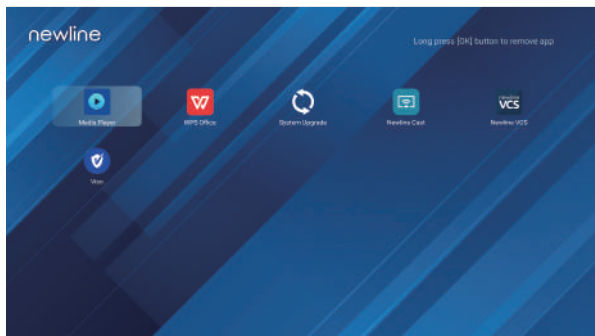

Media Player

Select **Media Player** or press the button USB on the remote control to enter the media player. This page include Document, Video, Photo, Music and Disk, as shown in the following figure.

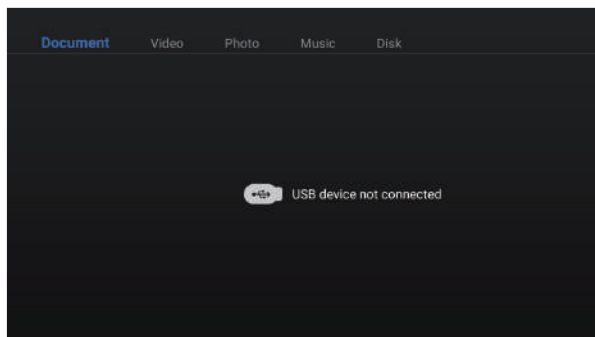

WPS Office

Select **WPS Office** to enter the WPS Office application. In this application, you can view office files, including excel, word, power point, and PDF files.

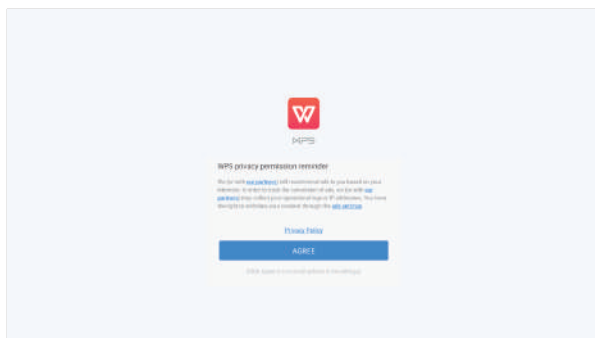

System Upgrade

Select the **System Upgrade** submenu to upgrade the system if a new version is available. In this interface, you can choose **Online Upgrade** or **USB Upgrade**.

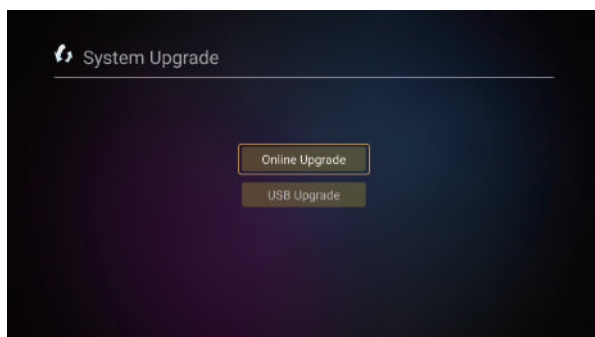

Viso

Viso is a remote display management solution that enables users to centrally manage the Newline displays from the comfort of their desk. Users can deploy and install apps, configure display settings, and push updates without communicating back and forth.

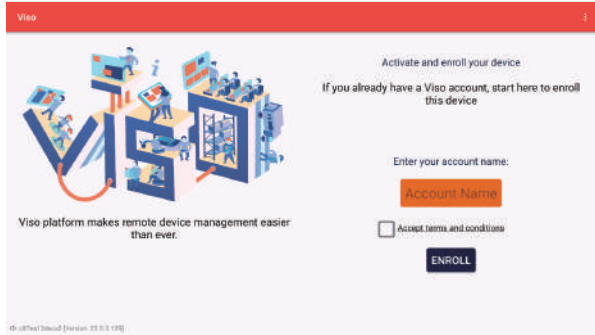

Menu Page

On the Home page, press the menu button \equiv on the remote control to view menu page. The menu items include Picture, Sound and System.

Press \leftarrow / \rightarrow / \wedge / \vee on the remote control to select a menu item, press **OK** to complete the menu switching and option setting in the menu. If you don't want the menu page, press \leftarrow to exit the menu page.

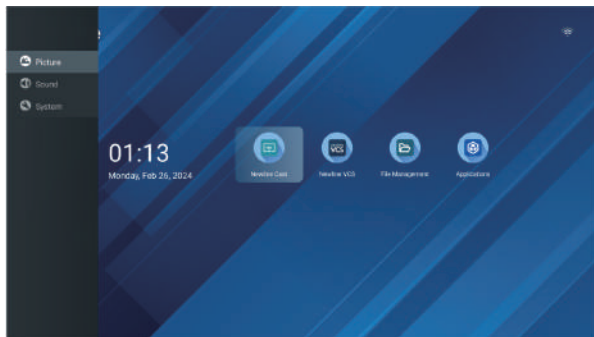

◆ Picture

Select the **Picture** item in the menu , in this interface including **Picture Mode**, **Backlight** and **Advanced Settings**.

- **Picture Mode:** Select **Picture Mode** to change the picture mode (Standard > Dynamic > Movie > Sport > Personal)
- **Backlight:** Press </> on the remote control to adjust the backlight.

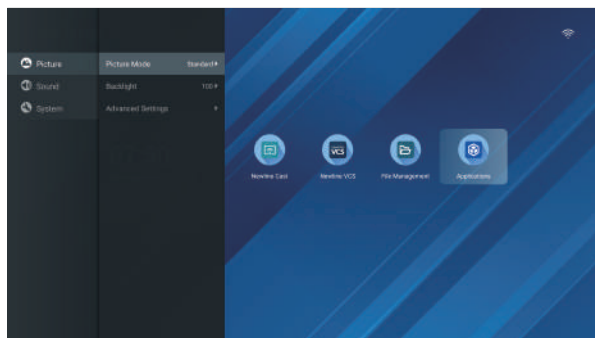

Advanced Settings

Select **Advanced Settings** to enter the following interface. Press ← to exit the setting.

- **Color Temperature:** Select this item to change the Color Temperature (Standard > Warm > Cool)
- **Dynamic Contrast:** Click the button to enable and disable the Dynamic Contrast.
- **HDMI PC/AV Mode:** Select this item to change the HDMI PC/AV Mode (Off > Low > Medim > High > Auto).
- **Noise Reduction:** Select this item to change the Noise Reduction (Off > Low > Medim > High > Auto).
- **Picture Reset:** Select this item to reset the picture.
- **Motion Estimate and Motion Compensation(MEMC):** Select this item to change the MEMC (Off > Low > Middle > High).
- **ECO Setting:** Select this item to change the ECO (Off > Low > High).

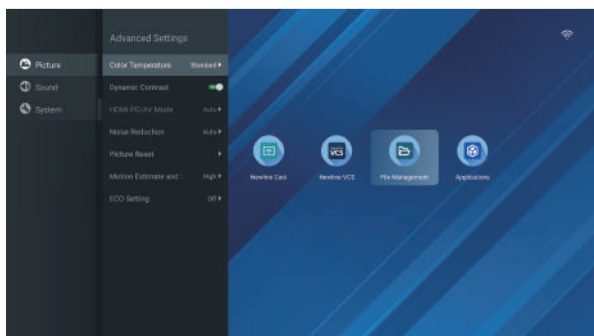

◆ Sound

Select the **Sound** item in the menu , in this interface including **Pure Sound, Sound Mode, Equalizer, Surround, Speaker, Audio Output Type** and **Advanced Settings**.

- **Pure Sound:** Click the button to enable and disable the Pure Sound.
- **Sound Mode:** Select **Sound Mode** to change the sound mode (Sports > Standard > Movie > Music > News). Press the button  to mute or unmute audio.
- **Equalizer:** Press </> on the remote control to adjust the equalizer.
- **Surround:** Click the button to enable and disable the Surround.
- **Speaker:** Select **Speaker** to change the Output Device (TV Speaker > SPDIF /Optical > HDMI-ARC).
- **Audio Output Type:** Select this item to change the audio output type (PCM > Passthrough > Auto).

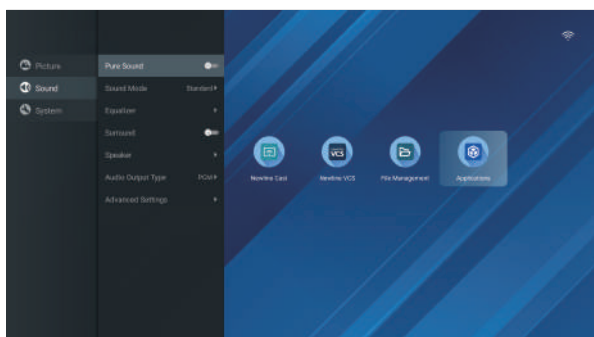

Advanced Settings

Select **Advanced Settings** to enter the following interface. Press ← to exit the setting.

- **Balance:** Press </> on the remote control to adjust the balance.
- **Surround Effect:** Select this item to change the surround effect.
- **SPDIF Audio Out Volume:** Press </> on the remote control to adjust the SPDIF audio out volume.
- **Sound Reset:** Select this item to reset the sound.

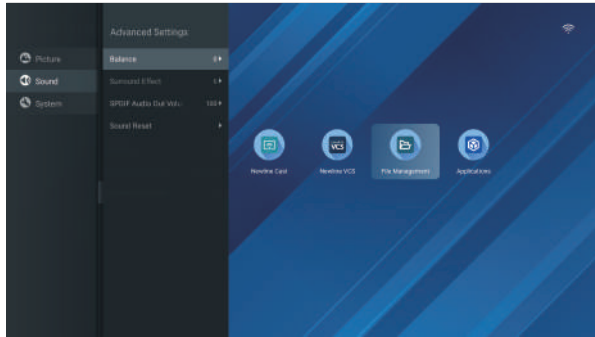

◆ System

Select the **System** item in the menu , in this interface including **Language, HDMI CEC Settings, HDMI Signal Format, Sleep Timer, Settings, Power Option** and **Auto Start VCS**.

- **Language:** Select **Language** to enter the setting interface of language.
- **HDMI CEC Settings:** Select **HDMI CEC Settings** submenu to enter the HDMI CEC settings interface. In this interface, Click the button to enable and disable the **CEC Control/Device Auto Power Off**. Select **CEC Device List** to check device list.
- **HDMI Signal Format:** Select this item to change the HDMI signal format.
- **Sleep Timer:** Select **Sleep Timer** to set the sleep time(15 min > 30 min > 45 min > 60 min > 90 min > 120 min > Off).
- **Settings:** Select **Settings** to enter the setting interface. In this interface, select **Settings** to enter the general settings. Select **Power** to enable and disable wake on network. Select **Available Space** to check system storage and memory size.
- **Power Option:** Select **Power Option** to choose **Power off** or **Sleep**.
- **Auto Start VCS:** Select **Auto Start VCS** to choose auto start VCS(On > Off).

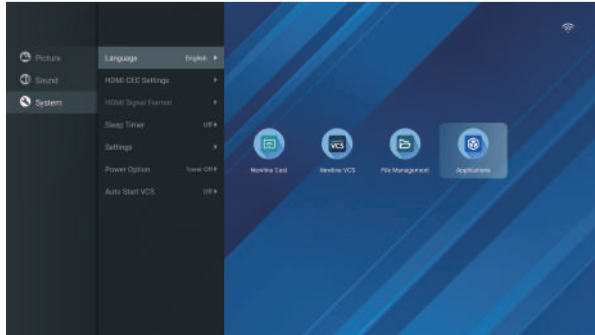

Input

Press the button  on the remote control to enter the input interface, all the input options display in this interface, including **HDMI 1**, **HDMI 2**, **HDMI 3**, **AV**, **USB**.

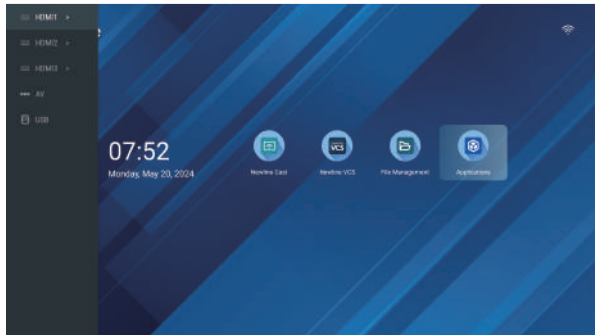

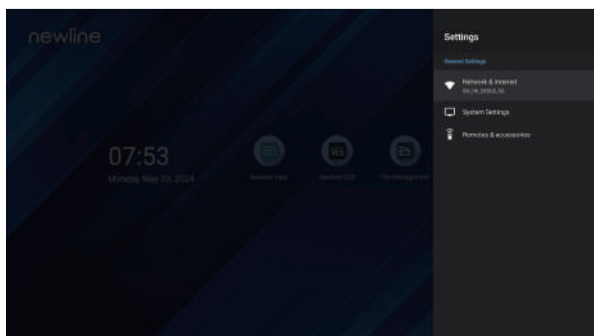

Settings

Press the button  on the remote control to enter the settings interface, this interface displays **Network & Internet**, **System Settings** and **Remotes & accessories**.



◆ Network & Internet

Select the **Network & Internet** or press the button  on the remote control to enter the network setting interface. You can view network status information, set **Wi-Fi**, **Add new network**, **Ethernet**, **Not connected Proxy** and **IP settings**. Press  button on remote control to return to the upper interface.

- **Wi-Fi:** Click the corresponding button to enable the Wi-Fi function.
- **Add new network:** Select this to add new network.
- **Ethernet:** Click the corresponding button to enable the Ethernet function. The user can customize settings to automatically obtain an IP address of the LAN or set a static IP address as needed.
- **Proxy settings:** Click the item to view proxy server.
- **IP settings:** Click the item to view IP server.

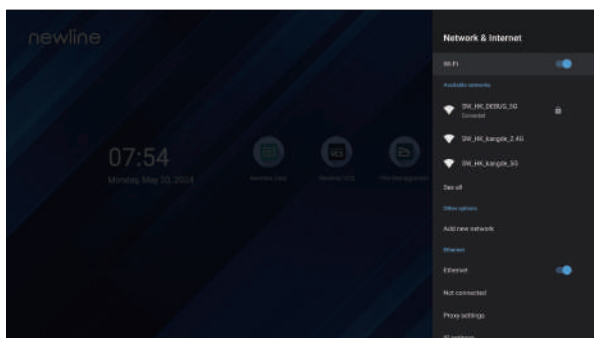

◆ System Settings

Select the **System Settings** to enter the system setting interface, including **About**, **Date & time**, **Keyboard**, **Screen saver** and **Reset**. Press ← button on remote control to return to the upper interface.

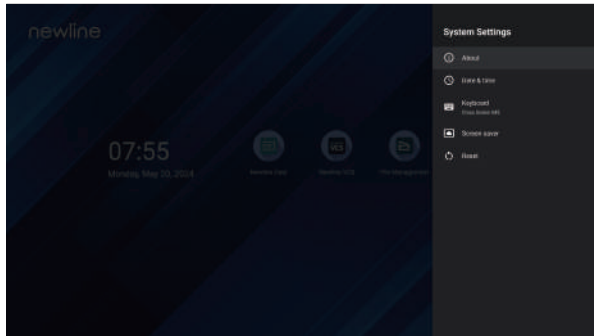

About

Enter **About** to check **Device name**, **Status**, **Model**, **Android OS version**, **V8 Version** and **SVN Version**. Select **Restart** to restart the device.

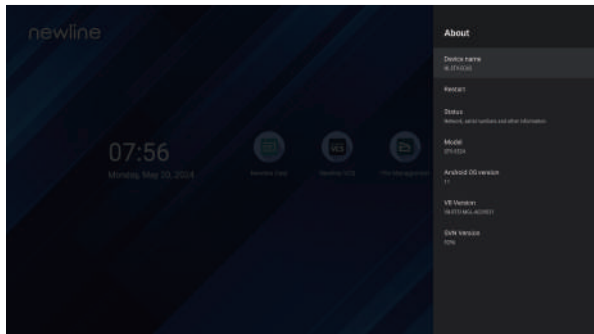

Date&Time

Select **Date &Time** to enter the setting interface. You can set **date & time**, select **time zone** and **Use 24-hour format** in this interface. Press ← button on remote control to return to the upper interface.

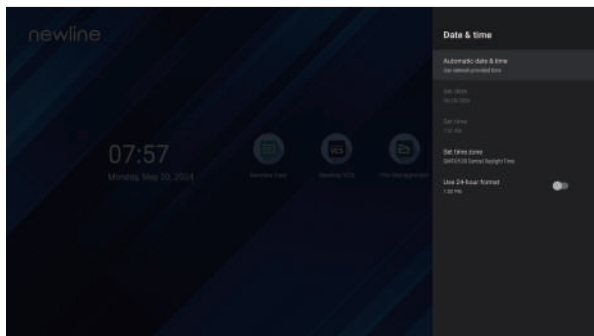

Keyboard

Select **Keyboard** to enter the keyboard interface. You can view **Current keyboard** in this interface.

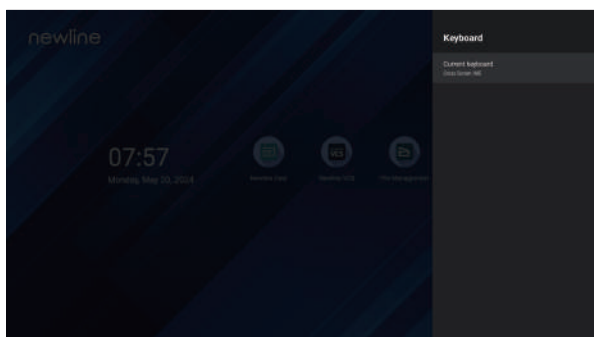

Screen saver

Select **Screen saver** to enter the setting interface. You can set **Screen saver**, **Start Screen Saver When Inactive** and **Start now** in this interface.

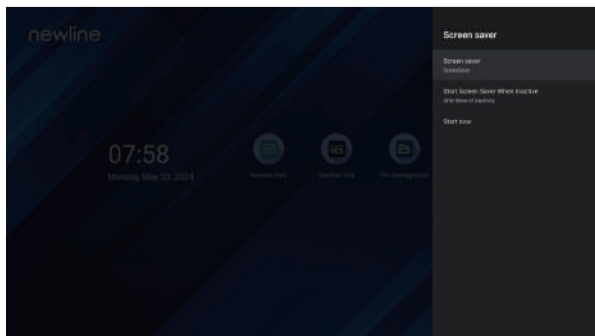

◆ Remotes & accessories

Select **Remotes & accessories** to searching for accessories.



6

Serial Port Control

The following table lists button controlling codes. The buttons share same functions with corresponding buttons on the remote controller:

Function	Controlling Codes	Return codes
Power off	7F 08 99 A2 B3 C4 02 FF 01 01 CF	7F 09 99 A2 B3 C4 02 FF 01 01 01 CF
Mute/ Unmute	7F 08 99 A2 B3 C4 02 FF 01 02 CF	7F 09 99 A2 B3 C4 02 FF 01 02 01 CF
Signal source	7F 08 99 A2 B3 C4 02 FF 01 06 CF	7F 09 99 A2 B3 C4 02 FF 01 06 01 CF
HDMI front / HDMI 1	7F 08 99 A2 B3 C4 02 FF 01 0A CF	7F 09 99 A2 B3 C4 02 FF 01 0A 01 CF
HDMI rear 1 / HDMI 2	7F 08 99 A2 B3 C4 02 FF 01 52 CF	7F 09 99 A2 B3 C4 02 FF 01 52 01 CF
HDMI rear 2 / HDMI 3	7F 08 99 A2 B3 C4 02 FF 01 53 CF	7F 09 99 A2 B3 C4 02 FF 01 53 01 CF
USB-C (Rear)	7F 08 99 A2 B3 C4 02 FF 01 55 CF	7F 09 99 A2 B3 C4 02 FF 01 55 01 CF
VOL -	7F 08 99 A2 B3 C4 02 FF 01 17 CF	7F 09 99 A2 B3 C4 02 FF 01 17 01 CF
VOL +	7F 08 99 A2 B3 C4 02 FF 01 18 CF	7F 09 99 A2 B3 C4 02 FF 01 18 01 CF
Menu	7F 08 99 A2 B3 C4 02 FF 01 1B CF	7F 09 99 A2 B3 C4 02 FF 01 1B 01 CF
Home page	7F 08 99 A2 B3 C4 02 FF 01 1C CF	7F 09 99 A2 B3 C4 02 FF 01 1C 01 CF
Return (exit)	7F 08 99 A2 B3 C4 02 FF 01 1D CF	7F 09 99 A2 B3 C4 02 FF 01 1D 01 CF
OK	7F 08 99 A2 B3 C4 02 FF 01 2B CF	7F 09 99 A2 B3 C4 02 FF 01 2B 01 CF
←	7F 08 99 A2 B3 C4 02 FF 01 2C CF	7F 09 99 A2 B3 C4 02 FF 01 2C 01 CF
→	7F 08 99 A2 B3 C4 02 FF 01 2D CF	7F 09 99 A2 B3 C4 02 FF 01 2D 01 CF

↑	7F 08 99 A2 B3 C4 02 FF 01 2E CF	7F 09 99 A2 B3 C4 02 FF 01 2E 01 CF
↓	7F 08 99 A2 B3 C4 02 FF 01 2F CF	7F 09 99 A2 B3 C4 02 FF 01 2F 01 CF
Set volume	7F 08 99 A2 B3 C4 02 FF 05 XX CF	7F 09 99 A2 B3 C4 02 FF 01 2B 01 CF NOTE: XX indicates the value of volume (0- 100), corresponding to the hexadecimal number system (00 - 64).
Query the firmware version number	7F 08 99 A2 B3 C4 02 FF 01 3D CF	7F 09 99 A2 B3 C4 02 FF 01 3D XX CF Note: XX indicates version (20211110183518)
Increase backlight brightness	7F 08 99 A2 B3 C4 02 FF 01 47 CF	7F 09 99 A2 B3 C4 02 FF 01 47 01 CF
Decrease backlight brightness	7F 08 99 A2 B3 C4 02 FF 01 48 CF	7F 09 99 A2 B3 C4 02 FF 01 48 01 CF
Set the value of backlight brightness	7F 08 99 A2 B3 C4 02 FF 09 XX CF	7F 09 99 A2 B3 C4 02 FF 09 XX 01 CF NOTE: XX indicates the value of backlight brightness (1- 100), corresponding to the hexadecimal number system (01- 64).
Settings	7F 08 99 A2 B3 C4 02 FF 01 20 CF	7F 09 99 A2 B3 C4 02 FF 01 20 01 CF
Mute On	7F 09 99 A2 B3 C4 02 FF 0F 00 CF	7F 09 99 A2 B3 C4 02 FF 0F 00 01 CF
Mute Off	7F 09 99 A2 B3 C4 02 FF 0F 01 CF	7F 09 99 A2 B3 C4 02 FF 0F 01 01 CF
Switch Backlight On	7F 09 99 A2 B3 C4 02 FF 0E 01 CF	7F 09 99 A2 B3 C4 02 FF 0E 01 01 CF
Switch Backlight Off	7F 09 99 A2 B3 C4 02 FF 0E 00 CF	7F 09 99 A2 B3 C4 02 FF 0E 00 01 CF

<p>Backlight brightness</p>	<p>7F 08 99 A2 B3 C4 02 FF 01 49 CF</p>	<p>7F 09 99 A2 B3 C4 02 FF 01 49 XX CF NOTE: XX indicates the value of backlight brightness (1 - 100), corresponding to the hexadecimal number system (01 - 64).</p>
<p>Return to system state of the previous options</p>	<p>7F 08 99 A2 B3 C4 02 FF 0A 00 CF</p>	<p>7F 08 99 A2 B3 C4 02 FF 0A 00 AB CF</p>

7

Formats Supported by Multi-media

.....

Media category	Formats
Photo	JPEG, BMP, PNG.
Video	.mkv/.wmv/.avi/.mp4/.mpeg/.mov/.dat
Audio	.mp3/.wma/.m4a/.mp4/.aac

8

FAQ & Troubleshooting

Before you contact the technical support staff, please identify a fault according to the following table. If the fault cannot be restored based on the solutions, contact your local distributor for help. For your safety, please do not repair the unit on your own.

Failure	Solution
No image.	<ul style="list-style-type: none"> • Check whether the power plug is inserted into the power outlet and whether the display is powered on. • Check whether the video and audio input cables are connected correctly. • Check to ensure the correct source is selected. • Check the settings on image brightness and contrast.
Image is normal, but no sound.	<ul style="list-style-type: none"> • Check the volume. • Check whether the MUTE button on the remote controller is pressed.
The image is black and white.	<ul style="list-style-type: none"> • Modify the color settings. • Check the color settings.
Image or sound is interrupted.	<ul style="list-style-type: none"> • Turn off other devices surrounding the screen to check again, if any surrounding devices are causing the interference, try moving them away from the screen. • Do not share the same power outlet with other electric appliances that could interference.
The remote controller fails.	<ul style="list-style-type: none"> • Change the batteries. • Clean the signal emitter at the top of the remote controller. (Check whether it is blocked.) • Check contacts of the batteries.

The following symptoms are not faults:

- A very few of constantly bright or dark pixels, such as tiny red, blue, green or dark points, may exist on the screen. This symptom is not a fault and does not affect running functions of the machine.
- Slight sound may occur due to the backlight adjustment or ventilation. This is a normal symptom.
- The image and sound are normal. However, you can sense static electricity when you touch the screen and metal back cover. This is a normal symptom.

9

Maintenance Tips

- Do not install or place the machine near the heat source.
- Do not install or place the machine under directly sunlight, or dust /damp place.
- Do not install or place the machine in the places with mechanical vibration and vulnerable to impact.
- Please keep the machine stay away from grid, large metal objects, radar stations and other equipment.
- Do not use chemical reagents to wipe the machine body, solvent may cause deterioration or damage to the shell paint. If have dirt bilge, wipe it with drying warm cloth after cutting off power source. Display touch screen can be wiped gently with a clean soft cloth.
- Do not power on and off the machine frequently, so as not to affect the service life of the machine. After normal shutdown, please wait three minutes before starting up. If not in use for a long time, please turn off the power and unplug the machine.
- Do not set the display brightness and contrast to the maximum for a long time to extend the service life of the screen.
- Do not use hard objects to write on the touch screen, so as not to scratch the screen and affect the display effect.